



AMERICA'S FOOT SWITCH LEADER

## **Infrared Wireless Footswitch Operators Manual**



## **GUARANTEE**

All wireless footswitches sold by Linemaster Switch Corporation are fully guaranteed as to materials and workmanship for a period of 1 year. Linemaster Switch reserves the right to perform guarantee service operations in its own factory, at an authorized repair station, or in the customer's installation.

Our obligation under this guarantee is limited to repairing, or at our option, replacing any defective parts of our equipment, except fuses or batteries, without charge, if defects occur in normal service.

Claims for damage in shipment should be filed promptly with the transportation company. All correspondence covering the instrument should specify the model and serial number.

Linemaster Switch Corporation will make available on request such circuit diagrams, component drawings, component parts lists, descriptions, calibration instructions, or other information which will assist the users or appropriately qualified technical personnel to repair those parts of the equipment which are classified by Linemaster Switch as repairable.

Tel: (860) 974-1000

Fax: ( 860) 974-0691

Fax: ( 800) 974-3668 U.S.A. Only

[www.linemaster.com](http://www.linemaster.com)

---

## Safety

The information presented in this section is important for the safety of both the patient and the operator and also serves to enhance equipment reliability. This section describes how the terms Warning, Caution, Important, and Note are used throughout the manual. In addition, Linemasters' standard equipment symbols are defined.

### General Information

#### General Use

If the foot switch is cold to the touch or below ambient temperature, allow it to stabilize before use.

The use of ACCESSORY equipment not complying with the equivalent safety requirements of this equipment may lead to a reduced level of safety of the resulting system. Consideration relating to the choice shall include:

- use of the accessory in the PATIENT VICINITY
- evidence that the safety certification of the ACCESSORY has been performed in accordance to the appropriate IEC 60601-1 and/or IEC 60601-1-1 harmonized national standard.

Periodically, whenever the integrity of the switch is in doubt, test all functions.

### Responsibility of the manufacturer

Linemaster Switch is responsible for the effects on safety, reliability, and performance if:

- Assembly operations, extensions, readjustments, modifications, or repairs are carried out by persons authorized by Linemaster Switch Corporation.
- The switch is used in accordance with the instructions for use.

---

## Definitions of Terminology

Four types of special notice are used throughout this manual. They are: Warning, Caution, Important, and Note. The warnings and cautions in this safety section relate to the equipment in general and apply to all aspects of the foot switch. Be sure to read the other chapters because there are additional warnings and cautions, which relate to specific features of the footswitch.

- Warning-** A WARNING indicates a potentially hazardous situation, which, if not avoided, could result in death or serious injury.
- Caution-** A CAUTION indicates a potentially hazardous situation which, if not avoided, may result in minor or moderate injury. Cautions are also used to avoid damage to equipment.
- Important-** An IMPORTANT notice indicates an emphasized note. It is something you should be particularly aware of, something not readily apparent.
- Note-** A NOTE indicates a particular point of information, something on which to focus your attention.

## Warnings

- Plasma Displays-** Plasma video displays can seriously affect the operation of this device. Plasma video displays can increase the switch activation times significantly or prevent switch operation altogether.
- Do not use in the vicinity of plasma video displays.
- Accidental spills-** In the event that fluids are accidentally spilled on the receiver, take the receiver out of operation and inspect for damage.
- Electric shock-** To reduce the risk of electrical shock do not remove any covers. Refer servicing to qualified personnel.
- Explosion hazard-** Do not use this equipment in the presence of flammable anesthetics.
- Grounding-** Do not defeat the three-wire grounding feature of the AC adapter. A dangerous shock hazard may result.
- Interfacing to equipment-** Foot switches must be interfaced with other equipment. Be certain to consult manufacturers specifications to maintain safe operation.

---

## Cautions

- Annual servicing-** For continued safety and performance of the switch, it is recommended that the functionality and electrical safety of the switch be verified on an annual basis by an authorized Linemaster representative.
- Daily testing-** It is essential that the foot switch be inspected everyday or before use.
- Performance-** Report all problems experienced with the footswitch. If the footswitch is not working properly, contact your service representative for service. The footswitch should not be used if it is not working properly.

## Important

- Loss of signal-** If the receiver does not receive a signal from the transmitter for a period of 1050ms it will shut off the outputs. However, once the transmission is restored the receiver will function normally.

The infrared wireless foot switch operates in a non-line of site mode with 360 degrees of reception. However every application is different. You may need to adjust the position of the receiver or transmitter to obtain optimal performance.

A maximum of four transmitters may be operated in a single room, in any of the configurations listed.

4 separate transmitters and receivers

2 separate transmitters and 2 receivers along with 2 transmitters paired to 1 receiver

2 sets of transmitters paired to 2 separate receivers

---

## Electromagnetic Interference

This device has been tested and found to comply with the limits for medical devices to the EN 60601-1-2 (2002), Medical Device Directive 93/42/EEC. These limits are designed to provide reasonable protection against harmful interference in a typical medical installation.

However, because of the proliferation of radio-frequency transmitting equipment and other sources of electrical noise in the health-care and home environments it is possible that high levels of such interference due to close proximity or strength of a source, may result in disruption of performance of this device.

This equipment generates, uses, and can radiate radio frequency energy and, if not installed and used in accordance with these instructions, may cause harmful interference with other devices in the vicinity. Disruption or interference may be evidenced by erratic or incorrect functioning. If this occurs, the site of use should be surveyed to determine the source of this disruption, and actions taken to eliminate the source.

The user is encouraged to try to correct the interference by one of the following measures:









- Turn equipment in the vicinity off and on to isolate the offending equipment.
- Reorient or relocate the other receiving device.
- Increase the separation between the interfering equipment and this equipment.
- If assistance is required, contact your Linemaster Switch Representative.

---

## Equipment Symbols

The following is a list of symbols used on products manufactured by Linemaster Switch.  
Some symbols may not appear on your unit.

**Table 1-2. Equipment Symbols**

	<b>ATTENTION: Consult accompanying documents</b>
	<b>ALTERNATING CURRENT (AC)</b>
	<b>EARTH GROUND</b>
	<b>POWER OFF: disconnection from the mains</b>
	<b>POWER ON: connection to the mains</b>
	<b>LOW BATTERY</b>
	<b>FOR INDOOR USE ONLY</b>
	<b>TYPE B EQUIPMENT-</b> Type B equipment is suitable for intentional external and internal application to the patient, excluding direct cardiac application.

---

## Channel/Coding

The IR foot switch has four distinct channel capabilities. This allows up to four different switches to be used in the same area simultaneously.

The channel is identified in the serial number of the units. See example below.

The channel also appears on a label on top of the units.

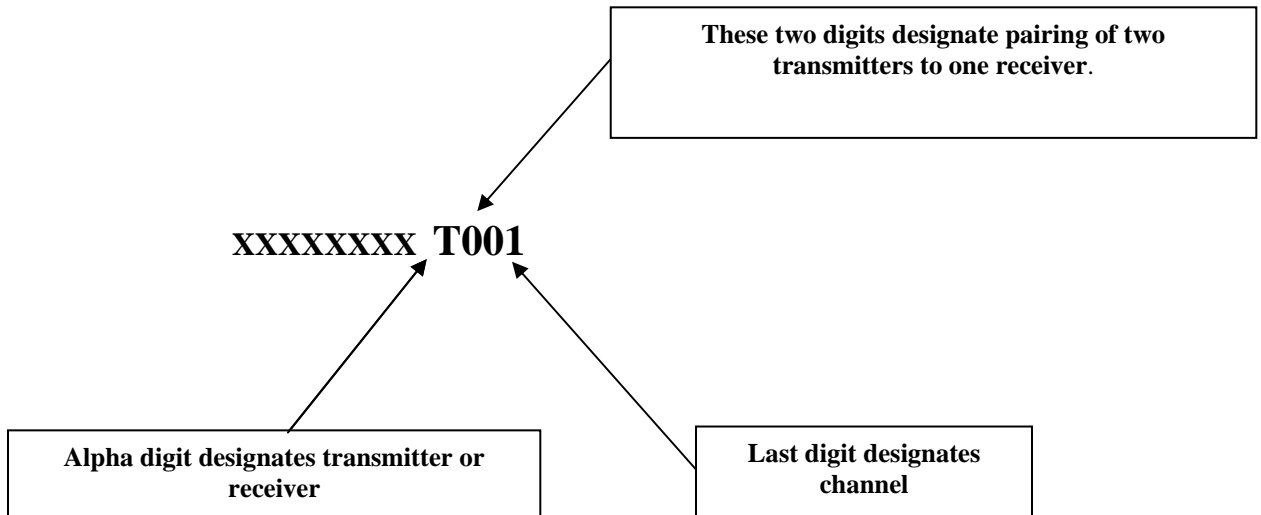

In addition to the four channels each manufacturer has its own code encryption. This assures that different manufacturers with the same channel marking can be used in the same area simultaneously with no interference. The manufacturers code is embedded into the model number as shown below. It also appears on a label on the top of the units.

SP-9970214-XXX XXXXXX

These three digits denote the manufacturers code.

XXX

**example A**

XXX/XXX

**example B**

### Unit label:

The first two or three digits denote the manufacturer code, the last digit is the channel. If label on the receiver looks like example B, it means that the receiver is paired to two transmitters.

## Receiver Front View (Shown with optional battery pack)

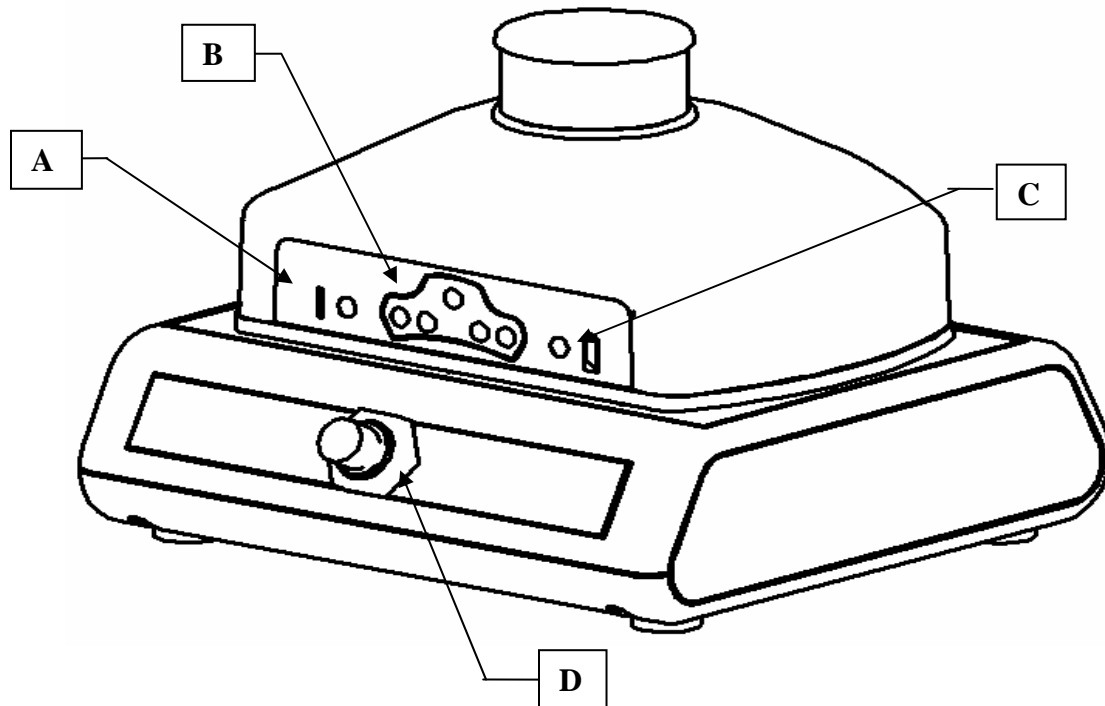

	Name	Description
A	Power On indicator. If you have the optional battery powered receiver it is also the low battery indicator for the receiver.	Indicates the receiver is powered from the battery pack. The power On indicator has two functions. It flashes green to indicate the unit is powered and it will change color to red to indicate a low battery condition in the receiver. When it changes to red you have 7-8 hours of battery life remaining.
B	Switch function Indicators 1-5	LED's will light when switch(s) are actuated.
C	Transmitter low battery indicator	Red LED will flash when the batteries are close to the end of their life. The LED will flash for 3-4 hours. When LED stays on constantly there is 3-4 hours of battery life remaining. However, batteries should be replaced immediately.
D	On/Restart Switch (Receiver battery pack option only)	Battery powered receiver will automatically shut down after one hour if no activations are received from the transmitter. This switch must be pushed to restart the cycle.

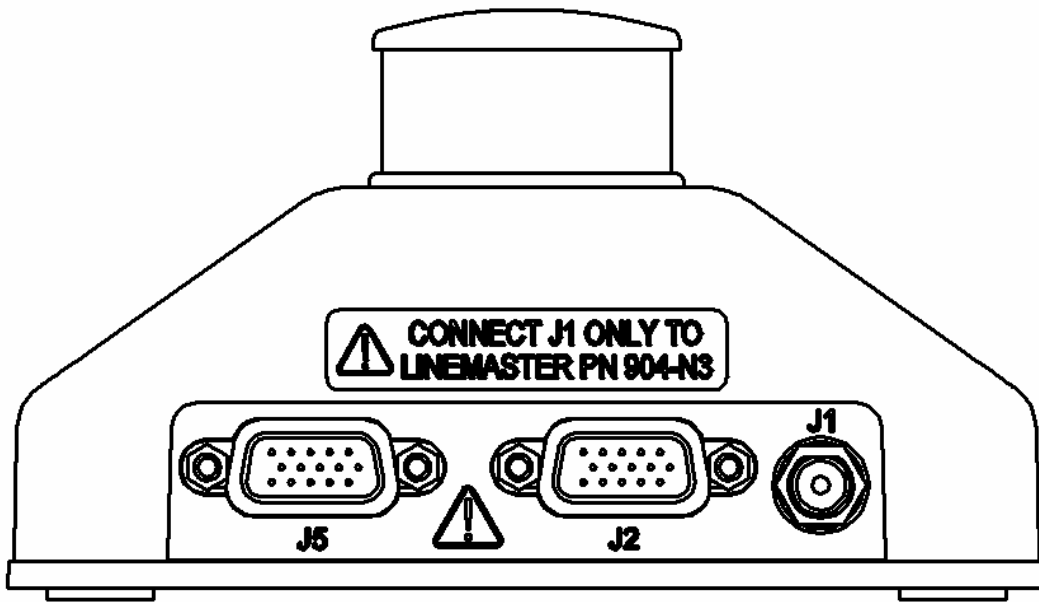

**Receiver Rear View**

	Description
J2, J5	Output Connector(s), J2 is an optional connector. Connectors are wired in parallel. For connection of interface cable(s) to the users equipment.
J1	Optional AC adapter connector. If you have a battery powered receiver this connector will not be here. Caution: AC adapter Use only Linemaster part number: Domestic- 120VAC, use part number 904-N3 International- 230VAC, use part number 904-G8 UK- 240VAC, use part number 904-H8

# Transmitter

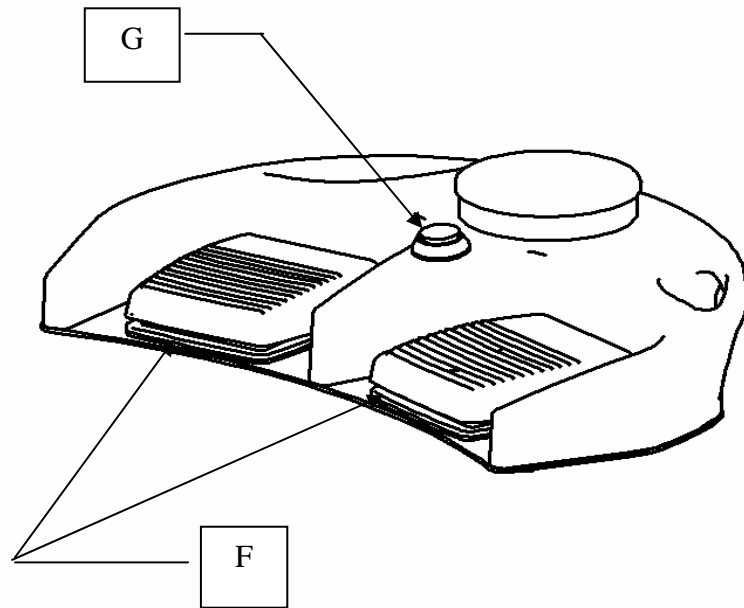

	<b>Description</b>
F	Primary switches Single or Dual Function
G	Optional switch

# Battery Replacement Transmitter/Receiver

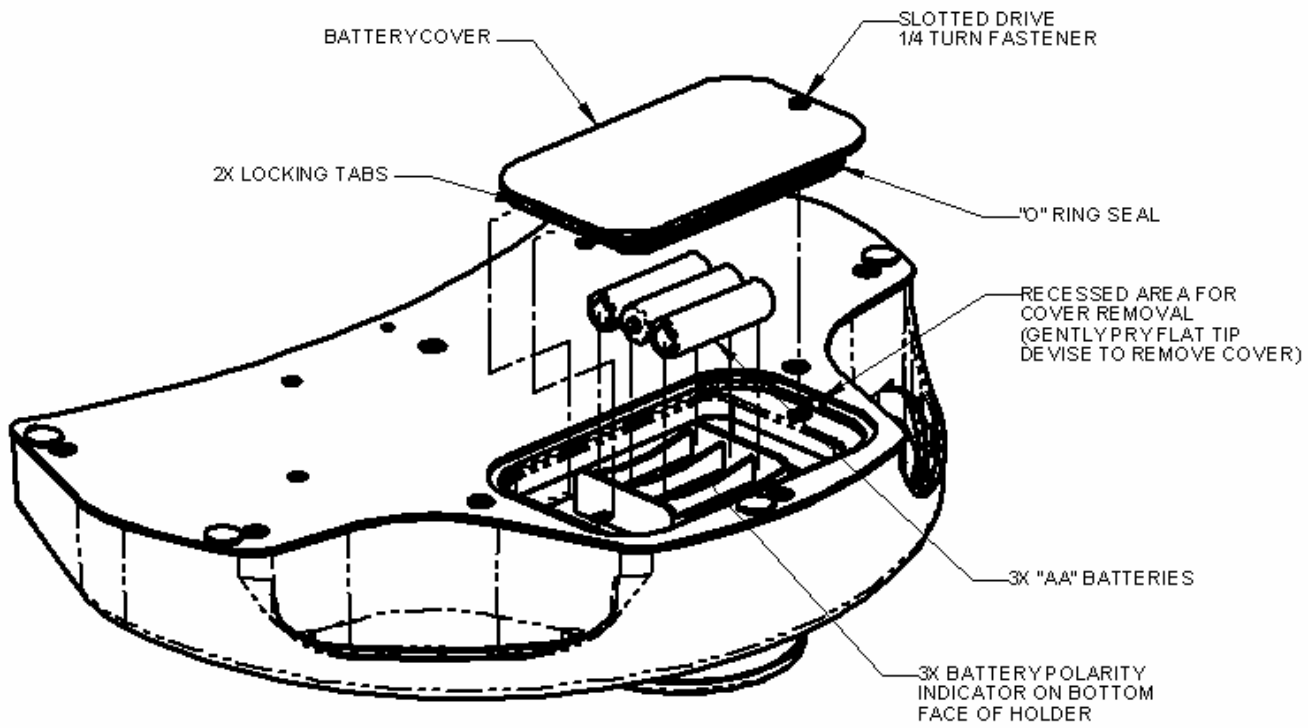

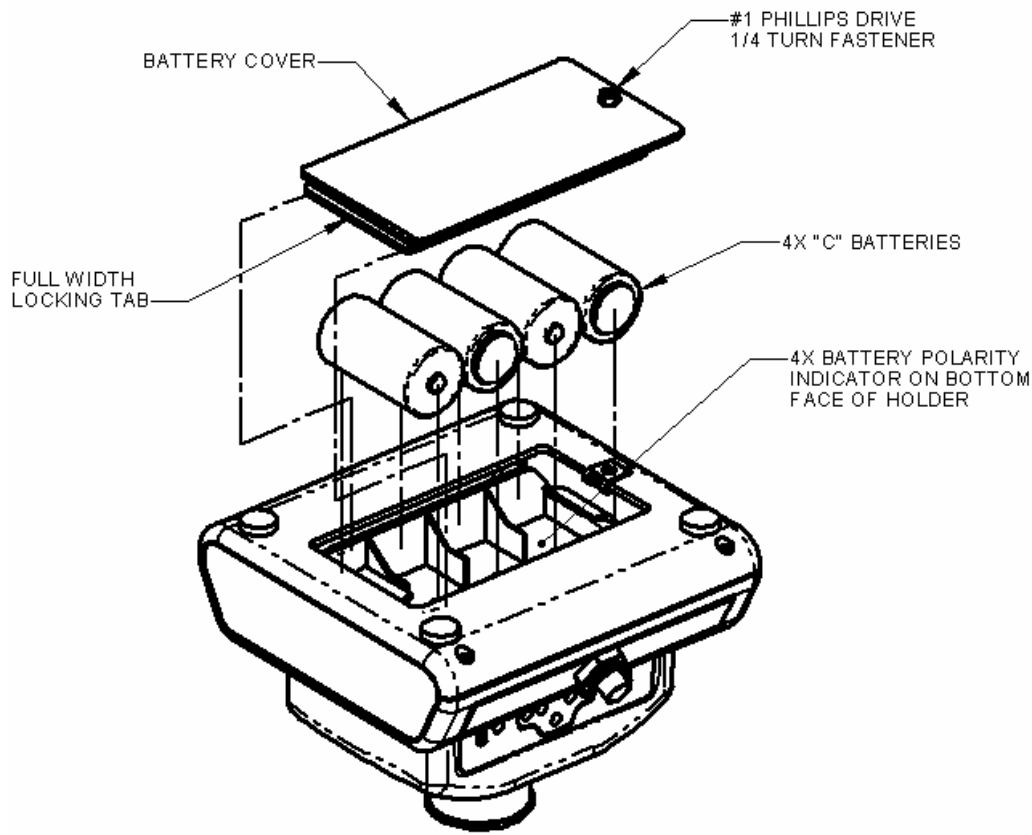

**Caution** Replace the batteries in the transmitter with high quality “AA” size Alkaline batteries as shown. Never mix manufacturers when replacing the batteries. Never mix old and new batteries. Care must be taken when replacing the batteries not to damage the o-ring seal on the battery cover. The o-ring seal should be replaced whenever it is damaged or its integrity is in question. Linemaster recommends the seal should be replaced at the minimum every third time batteries are replaced. When replacing the seal lubricate it with petroleum jelly. Replace the batteries in the receiver with high quality “C” size Alkaline as shown.

**Battery Leakage-** If the transmitter or receiver will not be used for an extended period of time, remove the batteries to prevent damage due to possible battery leakage.

**Battery disposal-** Follow the battery manufacturer’s recommendations or your hospital policy for the disposal of used batteries.

## Cleaning

The following cleaning instructions are provided.

---

---

### CAUTIONS:

**ABRASION-** Do not use abrasive cloth, sharp objects, or abrasive cleaners.

**DISCONNECTION-** Detach the interconnect cables and the AC adapter from the receiver.

**IMMERSION-** Do not immerse the receiver, cables or connectors under running water.

---

---

### Transmitter

The transmitter is *IP68 rated* and *can be* completely immersed briefly. Dampen a non-abrasive cloth with one of the following products; then wring out until slightly wet and gently rub soiled area until clean.

- Isopropyl alcohol
- Soap and water
- Cidex
- Sodium Hypochlorite 5.25% (Bleach) diluted 10:1

### Receiver

**CAUTION:** The receiver is *IPX1* rated and *cannot* be immersed.

---

---

Dampen a non-abrasive cloth with one of the following products; then wring out

---

---

until slightly wet and gently rub soiled area until clean.

- Isopropyl alcohol
- Soap and water
- Cidex
- Bleach Sodium Hypochlorite 5.25% (Bleach) diluted 10:1

Wipe any fluids from the surface of the receiver.

## Specifications

- Range: Typically 40 feet
- Switch Functions: Maximum of 5
- Latency: Typically 200 milliseconds
- Transmitter battery life: 200 hours @ 50 % Duty cycle typical
- Receiver battery life: 275 hours @ 50% duty cycle typical
- Power consumption (transmitter): Stand-by 100ua
- Power requirements (receiver): 6VDC @ 200ma, (Other voltages available)
- Receiver Output: SPST relay, 0.5 amp contacts
- 360 degree transmitter
- EN 60529 Degree of Protection IP68 (Transmitter)

## Certification

- Classified to IEC/UL 60601.1 Medical electrical equipment by Underwriter's Laboratories, Inc with respect to fire, shock, and mechanical hazards in accordance with IEC/UL 60601.1.
- Classified with respect to electric shock, fire, mechanical, and other specified hazards only, in accordance with Can/CSA C22.2 No. 60601.1

## EMC Standards

- EN60601-1-2: 2001
- IEC 1000-4-2: 1995 Electrostatic Immunity
- IEC 1000-4-3: 1995 Radiated Electromagnetic Field Immunity @ 10uv/m
- IEC 1000-4-4: 1995 Electrical Fast Transients Immunity
- IEC 1000-4-5: 1995 Surge Immunity
- IEC 1000-4-6: 1996 Conducted RF Immunity
- IEC 1000-4-8: 1993 Power Frequency Magnetic Field Immunity
- IEC 1000-4-11: 1994 Voltage Dips and Variations
- EN 55011: 1998 Radiated and Conducted Emissions, Group 1 Class B
- FCC Part 15 Radiated and Conducted Emissions, Class B
- IEC 61000-3-2: 2000 Power Harmonics Class A
- IEC 61000-3-3: 1995 + A1: 2001 Voltage Fluctuation, Section 5

## Size

Transmitter:	14.0in x 10.0in x 3.0in
Receiver:	5.0in x 3.5in x 2.75in
Receiver (Battery Powered):	5.5in x 5.25in x 4.5in

## Weight

Transmitter:	5.5 lbs w/batteries
Receiver:	.45lbs
Receiver (Battery Powered):	1.7lbs