

MOTOR SPEED CONTROL FOOT SWITCH



The LINEMASTER Motor Speed Control foot switch offers the precision required when operating variable speed equipment. This ergonomic design uses a high impact polymeric

cover and base to give the user a durable, long lasting foot switch that will not rust or corrode. Standard models come equipped with dual cordsets to retrofit to many small

fractional horsepower universal AC/DC motors. Special variations are available upon request to meet the customer's needs. Only from Linemaster, American made innovation at work.

LINEMASTER Switch Corporation
Tel (860) 974-1000

29 Plaine Hill Road, P.O. Box 238

Woodstock, Connecticut 06281-0238 USA
Fax (800) 974-FOOT(3668)

www.linemaster.com/ds/motor/

MOTOR SPEED CONTROL

Precision in a Plastic Shell



FEATURES:

Variable control of small fractional horsepower Universal AC/DC motors only, leaving hands free



Half wave in the variable speed mode, full wave at full speed



Standard color is black; custom colors may be quoted on large O.E.M. orders.



2 holes provided for rigid mounting to floor or equipment



Optional steel weight plate available on request



Supplied with dual cordsets, single series plug or custom modified for the O.E.M.



Optional SPDT auxiliary off/on switch



SIZE (W x H x D):
2.25 in x 4.00 in x 6.34 in

WEIGHT:
1.21 lbs.

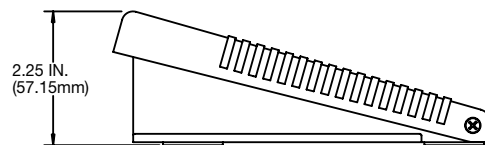
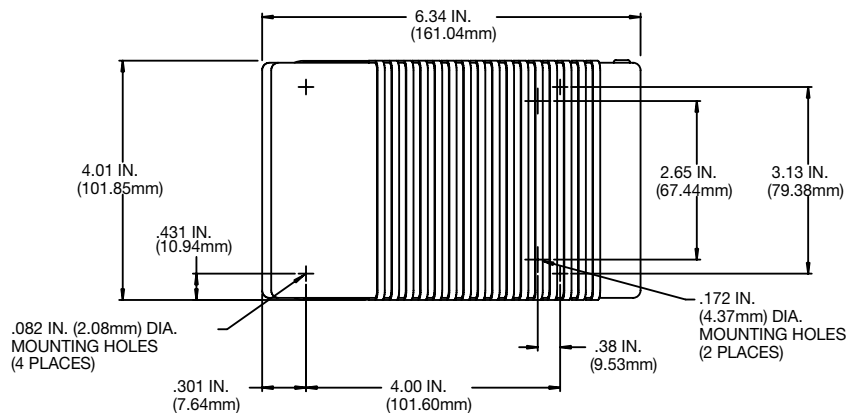

SPECIFICATIONS

| Agency Approvals | EN 60529 Degree of Protection | Catalog Number | Description | Cordset(s) | Electrical Ratings |
|------------------|-------------------------------|----------------|-----------------------|--|--------------------|
| | IP20 | 980-SC3 | Polymeric / Momentary | 6 ft. 18/3 SVT with 3-prong plug 1 ft. 18/3 SVT with mating receptacle | 6 A 125 VAC |
| | IP20 | 981-SC36 | Polymeric / Momentary | 6 ft. 18/3 SVT with outer jacket stripped back 1 ft. 18/3 SVT with outer jacket stripped back | 4 A 250 VAC |

www.linemaster.com/ds/motor/